

# .2P 180

BOX 166 TS

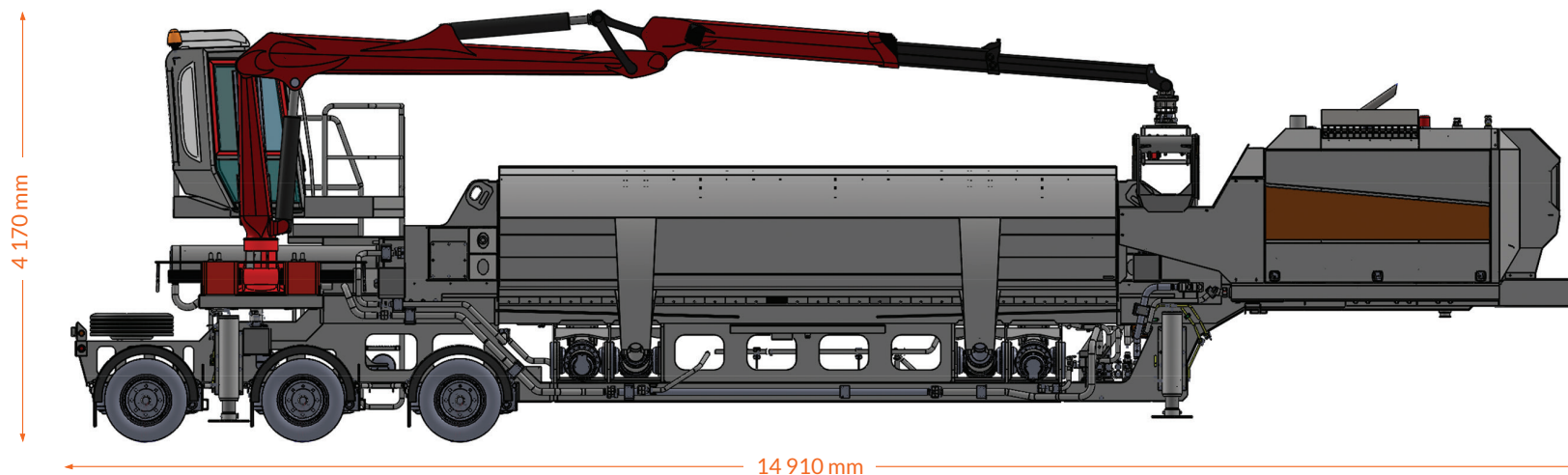

## .2P 180



### SPECIFICATIONS

Power unit	Diesel Tier 4 Final 278 Hp	Bale/Log size	1000 x 600 mm x variable
Box closing force	265 T per side	Fuel tank capacity	800 l
Pusher ram force	2 x 180 T	Hydraulic tank capacity	1200 l
Box length	6000 mm	Total weight	47 T
Box section closed	1000 x 600 mm		
Box section opened	2750 mm		

### MAIN FEATURES

- Adjustable pusher ram force (up to 180 T)
- Automatic lubrication system
- Hydraulic cooler
- Remote control
- Automatic cycle

### .Contact

LEFORT S.A.  
Rue Tahon, 1  
6041 - GOSSELIES

T. + 32 71 35.16.09  
@. info@lefort.com  
w. www.lefort.com

# .2P 180

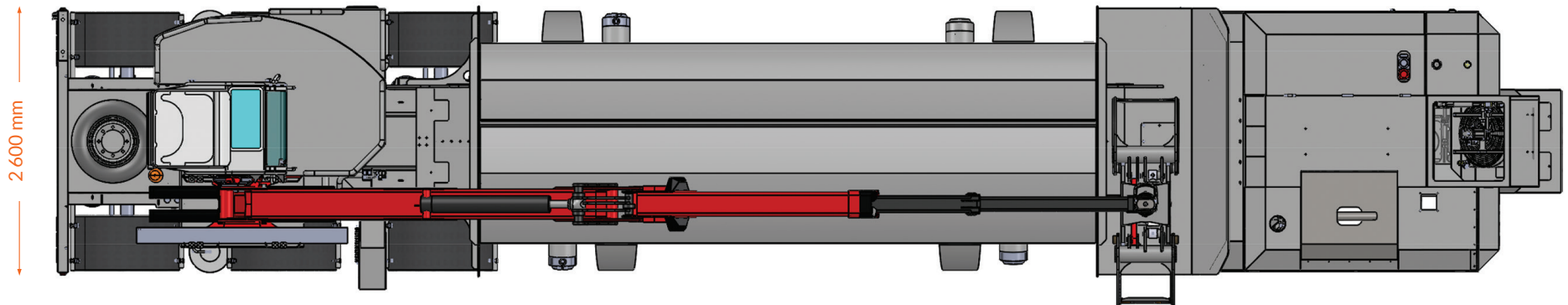

## OPTIONS

- Diesel (278 hp) or electric power unit (90 kw)
- Loading crane
- Heater for hydraulic tank
- Heater for diesel engine
- Modem

## VERSIONS

- Stationary
- Trax (track shoes)
- Portable (hydraulic jacks)
- Mobile (3 axles, road legal)



### .Contact

LEFORT S.A.  
Rue Tahon, 1  
6041 - GOSSELIES

T. +32 71 35.16.09  
@. info@lefort.com  
w. www.lefort.com