



# SINCRO 315 eko

## COMPACT GRANULATOR

**TRY BEFORE YOU BUY**

**TESTING LAB**

- Choose the most suitable equipment.
- Test your own material.
- Touch the result with your own hands.

The compact granulator model SINCRO 315 eko is designed to process rigid and flexible cables. With shredding and subsequent dry separation we are able to efficiently separate copper and aluminum from the insulation (plastic, rubber or paper). The unit can be fed manually or automatically with the addition of a conveyor depending on user's specific requirements.

Production up to 130 kg/h input material, variable depending on the material being processed.

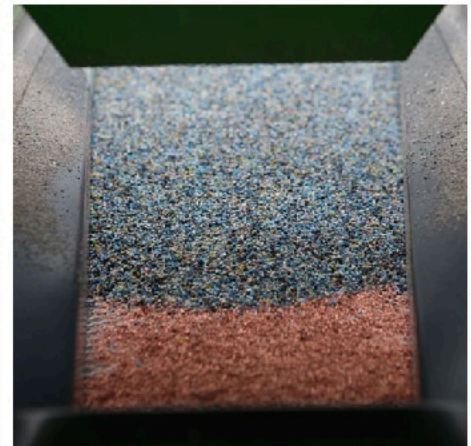

Cutting chamber

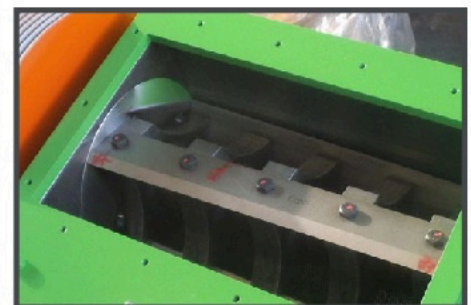

Easy maintenance



Manufactured in accordance to CE rules



### EXAMPLES OF INPUT MATERIALS



### EXAMPLES OF OUTPUT MATERIALS



### TECHNICAL SPECIFICATIONS

- Feeding: **Automatic or Manual**
- Rotor diameter: **170 mm**
- Number of rotating blades: **3**
- Number of fixed blades: **2**
- Screen sizes: **Ø 2-3-4-5-6-8 mm**
- Drive type: **V- belts**
- Installed power: **6,1 kW - 12,2 A**
- Voltage (standard): **400 V - 50 Hz**
- Separation tables: **60µ up to 200µ screen**
- Total weight: **458 kg**
- Noise level (as per sample test): **83 db(A)**

### PRODUCTION RATES

Input production rates are dependent on material input type and the screen size. The combination with the pre-shredder PMG improves its performance, reduces wearing out of components since iron parts are separated by the magnet installed on the conveyor, and reduces manpower.

### INPUT MATERIAL CAPABILITIES OF UNSHREDDED CABLE

- Flexible copper cable up to: **Ø22-25 mm**
- Rigid copper cable up to: **Ø20-22 mm**
- Aluminium cable up to: **Ø20-25 mm**

### OPTIONALS

- Rotary valve.  
(To ensure even feeding)
- Powder feed system.  
(For oily, sticky adhesive materials powder dosing system)
- Electronic connection.  
(For automatic operation with the pre-shredder)
- Double flywheel.
- Dust collection.
- Extended warranty.

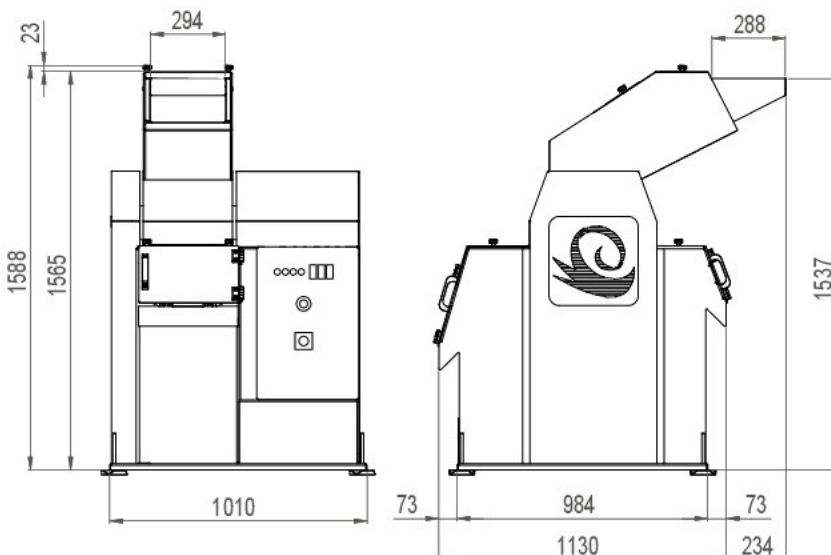

PRODUCTION COMPARATIVE GRAPHIC FOR MACHINE RANGE

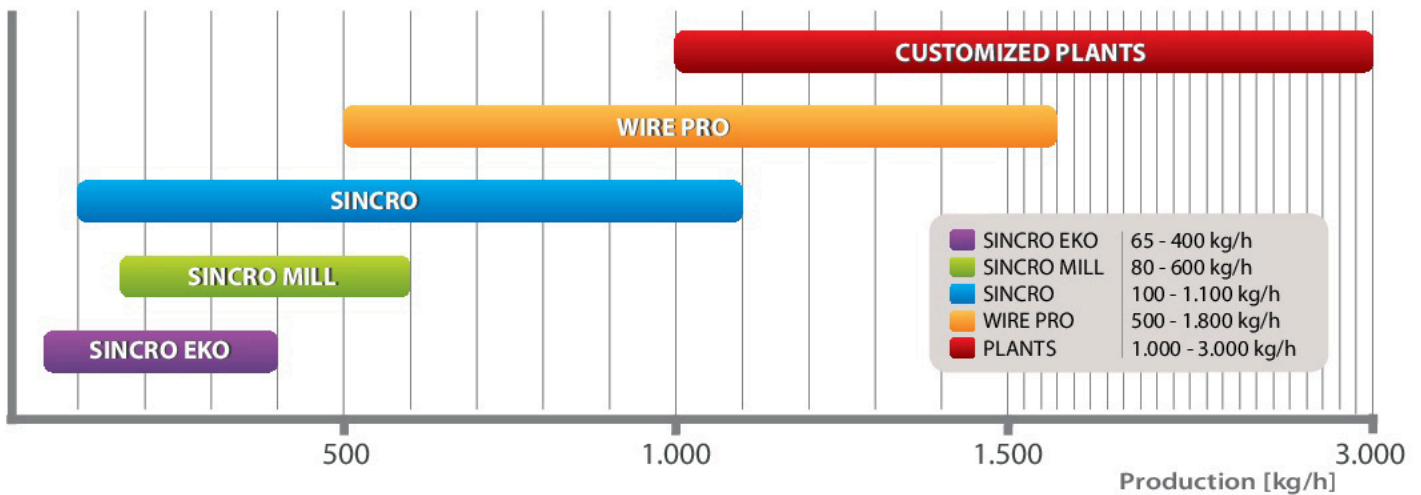

WHY CHOOSE SINCRO 315 EKO

- Best price/quality ratio.
- Rapid return of the investment.
- High resale value maintained over time.
- Compact, the perfect solution for small space.
- Ecological with low energy consumption and low noise level.
- Wide range of material that can be recycled.
- Easy to use and maintain.
- Fast and reliable service by factory trained technicians.

COMBINATIONS

All Sincro granulators can be combined to other Guidetti products to increase the production and quality:

- Pre-Shredder series PMG.
- Conveyor belt.  
(For the feeding of machines or to collect separated materials)
- Circular vibrating sieve.  
(To recover metal dust)
- Magnetic separator.



WARRANTY EXTENTION  
"YOU WORK WE CARE"

Warranty extensions can be purchased for up to 24-36 months from date of shipment. Extended warranty covers the replacement of parts that are defective. Wear items are excluded from all warranties. A yearly visit by a factory trained technician (2 or 3 depending on the extension purchased) will be made to verify the general condition of the equipment.



GUIDETTI EAST srl  
Str. I.V. Ispas, 14 - ap.3  
555300 Cisnadio - jud. SB - Romania  
web : [www.guidettieast.com](http://www.guidettieast.com)  
e.mail : [info@guidettieast.com](mailto:info@guidettieast.com)  
Ph. +40.724544260